

## TECHNICAL BULLETIN

## GASKETED PIPE TESTING REQUIREMENTS

## GASKETED PVC PIPE JOINTS

Gasketed joints used in segmented PVC pipe are typically available in a bell-and-spigot Integral Bell (IB), restrained joint integral bell (RJIB), and restrained joint (RJ) coupled configurations. These different joint types are illustrated in Figure 1 below. The benefits of using segmented PVC pipe include a smaller work site staging area, quick and efficient joint assembly, allowance of minor directional change at each joint, localized stress to terminate at each joint, and allows axial movement in the joint when subjected to external soil loads or thermal expansion and contraction.

The first ASTM Standards regarding the gasketed joint joining system were published in the Mid-1960's. In 1973 ASTM D3139 and ASTM D3212 were first published, followed by ASTM F477 in 1976. PVC gasketed joints have been in service for approximately 50 years. According to the PVC Pipe Association (formerly known as Uni-Bell) during this time over two million miles of gasketed PVC water and sewer pipelines have been installed across North America. This means approximately 528 million gasketed joints have been installed, assuming one gasketed joint per 20' length of pipe.

The gaskets found in the gasketed PVC pressure pipe joints are designed and proven to last for the entire life cycle of the PVC pipeline. Furthermore, gasketed joints are required to withstand the pressure rating of the pipe barrel. For example, gaskets used in AWWA C900 DR14 PVC pressure pipe must withstand the 315psi pressure rating of the pipe.

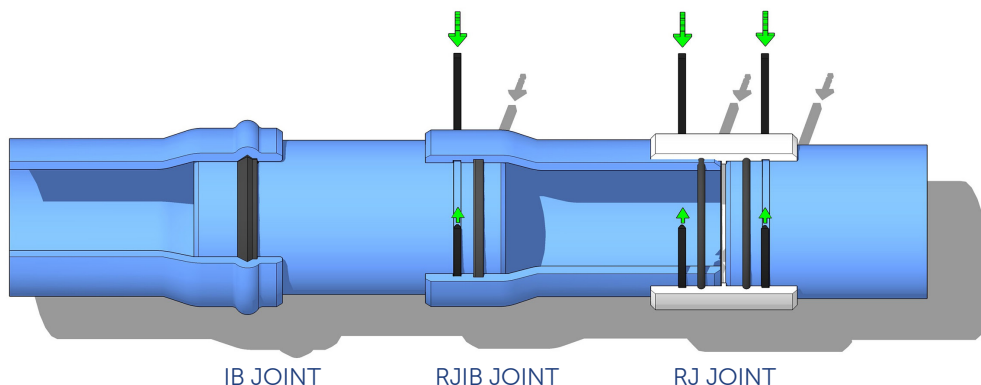

Figure 1 – Westlake Pipe & Fittings' Gasketed Joint Configurations

## GASKET MATERIAL PERFORMANCE REQUIREMENTS

All Westlake Pipe & Fittings gaskets are certified to industry standard ASTM F477, which tests for these properties:

- *Tensile Strength and Elongation* – determines proper tensile strength, 100% modulus and elongation.
- *Hardness* – proper hardness of the material.
- *Low-Temperature Hardness* - proper hardness of the material at low-temperatures (10°F-18°F).
- *Compression Set* – measures the ability for the material to return to its original size/thickness after prolonged compression.
- *Accelerated Aging* – resistance to deterioration over time.
- *Water Immersion* – resistance to absorption of water.
- *Oil Immersion* – resistance to absorption of oil.
- *Ozone Resistance* – resistance to ozone degradation.
- *Force Decay (Stress Relaxation)* – ensures the material maintains the proper amount of sealing force over its life cycle.

In addition to the ASTM F477 certification, gaskets used in Canadian gasketed gravity sewer PVC pipe are also certified to CSA 182.2. CSA 182.2 requires an additional water absorption test for TPE gasket material and a low-temperature flexibility test for vulcanized rubber gasket material. Gaskets used in Canadian gasketed PVC pressure pipe are also certified to the requirements of CSA B137.3.

## TECHNICAL BULLETIN

# GASKETED PIPE TESTING REQUIREMENTS

### GASKETED PVC PRESSURE JOINT REQUIREMENTS (ASTM D3139)

Westlake Pipe & Fittings’s gasketed joints are certified to ASTM D3139 for PVC pressure pipe. Gasketed joints certified to ASTM D3139 are required to pass internal pressure testing and a vacuum test.

#### Internal Pressure Testing

- The first part of the pressure testing requires an assembled joint at full angular deflection be pressurized to 50% of the pressure class of the pipe for 60 minutes. The pressure inside the joint is then increased to 2-1/2 times the rated pressure for another 60 minutes, with no leakage present during either duration.
- Then, the final part of the test requires the pressure be continuously increased from the previous 2-1/2 times rated pressure to the minimum short-term rupture requirement of the applicable pipe, without leakage. This pressure increase shall occur over a 60-70 second period. Refer to Figure 2 for example of test setup.
  - This test step ensures the gasketed joint is tested to the same internal pressure requirements of the pipe wall, for example AWWA C900 DR14 has a short-term rupture of 985 psi.

#### Vacuum Testing

- The deflected assembled joint shall withstand a vacuum of 75-kPa (22 in. Hg). Refer to Figure 2 for example of test setup.

### GASKETED PVC NON-PRESSURE JOINT REQUIREMENTS – ASTM D3212

Westlake Pipe & Fittings’ gasketed joints are certified to ASTM D3212 for non-pressure PVC pipe (gravity sewer and drainage). Gasketed joints certified to ASTM D3212 are required to pass an internal pressure test and vacuum test, with the following configurations:

- straight alignment with zero joint deflection (Figure 2),
- joint deflected to the maximum allowable angular joint deflection (Figure 3),
- and an assembly with a pipe vertical ring deflection of 5% applied (Figure 4)

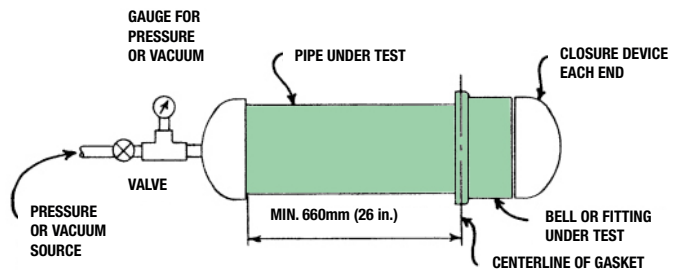

Figure 2 – ASTM D3212 Straight Alignment

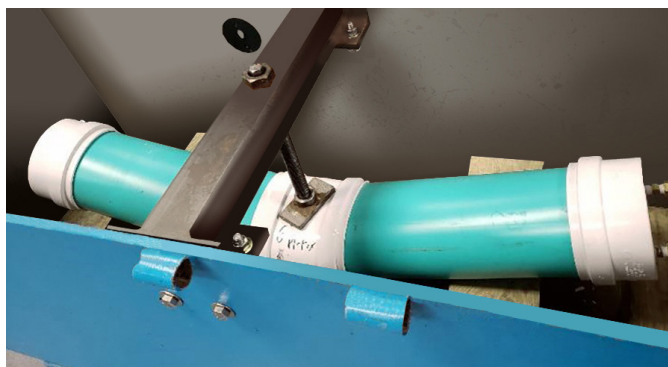

Figure 3 – Example of Angular Joint Deflection Setup for Pressure and Vacuum Tests for standard sewer fitting

## TECHNICAL BULLETIN

## GASKETED PIPE TESTING REQUIREMENTS

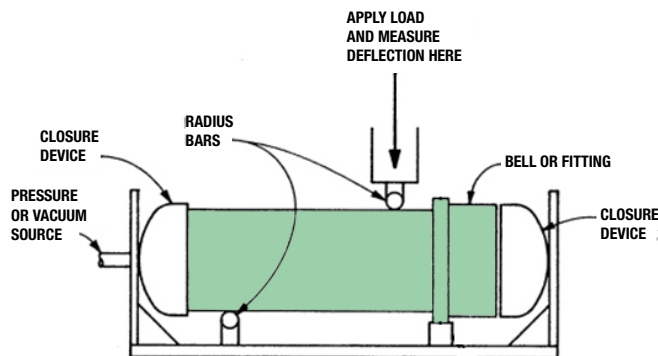

Figure 4 – ASTM D3212 Shear Deflection Test Setup (5% Ring Deflection)

**ASTM D3212 testing procedures:**

- The ASTM D3212 internal pressure test requires that a gasketed joint assemblies are pressurized to 10.8 psi (14.5 psi/100 kPa for CSA certified gravity sewer PVC pipe) for 10 minutes. Any visible leaks in the gasket joint assemblies constitutes a failure.
- The ASTM D3212 vacuum test requires that the gasketed joint assemblies are pressurized to a vacuum of 74kPa (22 in. HG), held for 10 minutes with less than a 3kPa (1 in. Hg) change. After the initial 10-minute pressurization, the assemblies are then tested for 10 minutes and shall not experience a pressure loss of more than 17 kPa (3 in. Hg) during the test period.

**REFERENCES**

- ASTM D3139 – *Standard Specification for Joints for Plastic Pressure Pipes Using Flexible Elastomeric Seals*  
 ASTM D3212 – *Standard Specification for Joints for Drain and Sewer Plastic Pipes Using Flexible Elastomeric Seals*  
 ASTM F477 – *Standard Specification for Elastomeric Seals (Gaskets) for Joining Plastic Pipe*  
 CSA 182.2 – *PSM Type Polyvinylchloride (PVC) Sewer Pipe and Fitting*

For further questions regarding gasket joints used across Westlake Pipe & Fittings' various PVC pipe systems please contact our technical services departments:

- Email – [technical@westlakepipe.com](mailto:technical@westlakepipe.com)
- Phone – 484-435-7474 (US) or 647-249-7368 (Canada)

This Technical Bulletin is published for general informational purposes only and is not intended to imply that these materials, procedures, or methods, are suitable for any particular job or should be relied on by the user. Materials, procedures, or methods may vary according to the particular circumstances, local building code requirements, design conditions, or statutory and regulatory requirements. While the information in this Technical Bulletin is believed to be accurate and reliable, it is presented without guarantee or responsibility on the part of Westlake Pipe & Fittings. User is solely responsible for usage of any material, procedure, or method contained herein.